



MODELO / MODEL

**ZUMEX 100 230V**

Nr. Desde/from 225909 hasta/to .....

**Rev 02**

INDICE / INDEX

Vista explosionada/Exploded view.....	Pag 2
Lista de piezas/ Part list.....	Pag 3
Esquema electrónico/Electronic diagram .....	Pag 6

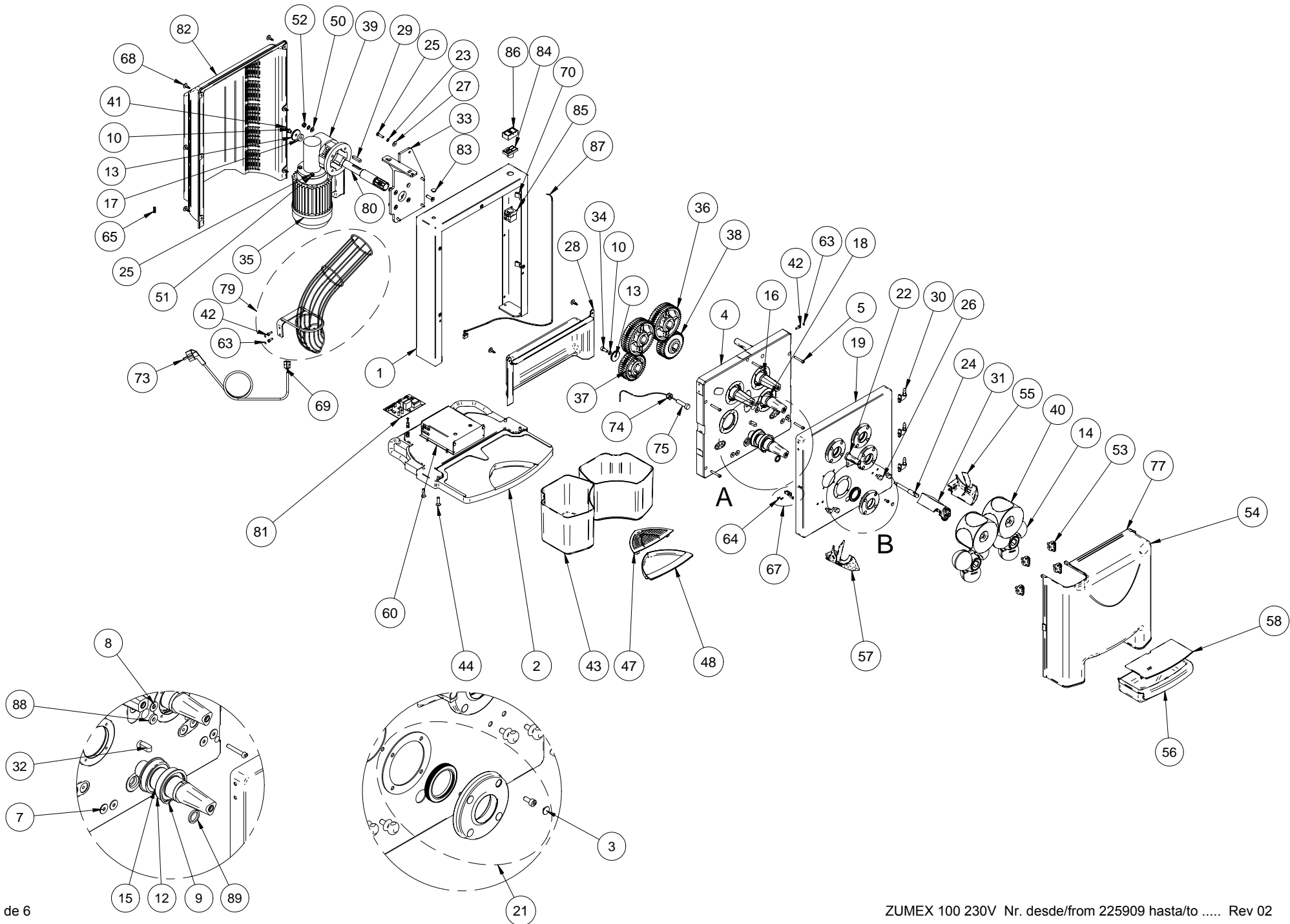

ZUMEX 100 230V

Los números entre parentesis se refieren modelos de máquinas, ver final de lista

Numbers between brackets refer to models of the machines, see end of list.

11/05/2007

NÚMERO DE PIEZA PART NUMBER	REFERENCIA REFERENCE	COMPUESTO POR COMPOSED BY	DESCRIPCIÓN	DESCRIPTION	CANTIDAD POR MAQUINA QUANTITY PER MACHINE	LOTE DISTRIBUCION DISTRIBUTION LOT
1	200.0262.005		CHASIS Z100/200	CHASSIS, Z-100/200	1	1
2	33.0036.000		BASE MÁQUINA AMARILL Z100/200 (1)	Z100/200 YELLOW MACHINE BASE	1	1
	200.3368.004		BASE Z100/200 GRAF (2) (3)	GRAPHITE Z100/200 BASE (2) (3)	1	1
	200.3367.004		BASE AMARILLA Z-250 (4)	Z-250 PEEL BUCKET (4)	1	1
	200.3369.004		BASE Z-250 GRAF (5) (6)	GRAPHITE Z-250 BASE (5) (6)	1	1
3	200.3364.000		TAPON SOPORTE RETEN	FASTENER SUPPORT CAP	16	1
4	13.494.000		CONJUNTO CARTER Z100/200 PINTADO	Z-100/200 PAINTED 16T GEARBOX	1	1
5	100.0903.111		TORNILLO DIN 912 M6 X 40 INOX	DIN 912 M-6x40 I SCREW	5	1
7	171.1806.000		JUNTA SILICONA 18,5 X 6 X 1,5	SILC. JOINT 18,5 X 6 X 1,5	4	1
8	171.1808.000		JUNTA SILICONA 18,5 X 8 X 1,5	SILC. JOINT 18,5 X 8 X 1,5	1	1
9	33.0015.000		KIT ANILLO SEG. DIN 472 I-62	SECURITY RING KIT	2	70
		4 Ud / 130.0013.062	ANILLO DE SEGURIDAD DIN 472 I-62	SECURITY RING		
10	105.0911.008		ARANDELA DIN 127 D8 INOX	DIN 127 D8 I WASHER	9	1
12	33.0011.000		KIT RODAMIENTOS 6007	6007 2RS BEARINGS KIT	4	16
		2 Ud / 140.0201.035	RODAMIENTO 6007 2RS	6007 2RS BEARINGS		
13	200.1110.001		ARANDELA PIÑON	PINION WASHER	5	1
14	33.0031.000		TAMBOR MACHO PLÁSTICO	LOWER PLASTIC PRESSING UNIT	2	2
15	33.0025.000		KIT SEPARADOR RODAMIENTOS INT	INTERNAL BEARINGS SEPARATOR KIT	1	10
		4 Ud / 200.1101.001	SEPARADOR INTERIOR	INTERNAL BEARINGS SEPARATOR		
16	210.1001.000		EJE TAMBOR HEMBRA METALICO	SS UPPER PRESSING SHAFT	2	1
17	200.1126.001		SUPLEMENTO SITI 25X9X7	25x9x7 SUPPLEMENT SHAFT SITI	1	1
18	210.1000.000		EJE TAMBOR MACHO METALICO	SS LOWER PRESSING SHAFT	2	1
19	220.0240.101		TAPA FRONTAL INOX.	STAINLESS STEEL FRONT	1	1
21	33.0010.000		KIT RETEN C/TORNILLOS V2.0	FASTENER W/SCREWS V2.0 KIT	4	48
		1 Ud / 200.3363.100	SOPORTE RETEN	FASTENER SUPPORT		
		1 Ud / 171.3001.000	JUNTA SOPORTE RETEN	FASTENER SUPPORT JOINT		
		4 Ud / 200.3364.000	TAPON SOPORTE RETEN	FASTENER SUPPORT CAP		
		4 Ud / 100.0903.085	TORNILLO DIN 912 M5 X 12	DIN 912 M5 X 12 I SCREW		
		1 Ud / 170.0001.002	RETEN MUELLE INOX 40 X 52 X 7 DL	INOX SPRING FAST 40 X 52 X 7 DL		
22	225.3305.000		TRASERA PORTACUCHILLAS	BACK BLADE SUPPORT	1	1
23	105.0911.006		ARANDELA DIN 127 D6 I.	DIN 127 D6 I WASHER	4	1
24	200.0142.000		VARILLA PORTACUCHILLA	BLADE SUPPORT ROD	1	1
25	100.0904.108		TORNILLO DIN 933 M6X25 I	DIN 933 M-6x25 I SCREW	8	1

26	33.0006.000		KIT SOPORTES PIVOTES CUÑAS EXT	PEEL EJECTORS PIVOT HOLDERS KIT	2	25
		2 Ud / 225.3320.000	SOPORTE CUÑA EXTRACTORA	PEEL EJECTORS PIVOT HOLDERS		
27	105.0916.006		ARANDELA DIN9021 D6 I	DIN 9021 D6 I WASHER	4	1
28	260.3427.003		FORRO CORTEZAS (1) (4)	v2.1 INJ. PEEL BUCKETS LINING (1) (4)	1	1
	260.3428.003		FORRO CORTEZAS INY MARRON (2) (5)	WOOD PELL BUCKETS LINING (2) (5)	1	1
	260.3431.003		FORRO CORTEZAS INY GRAF (3) (6)	GRAPHITE PEEL BUCKETS LINING (3) (6)	1	1
29	115.0000.036		CHAVETA 8X7X40	KEY 8 x 7 x 40	1	1
30	120.0002.002		BISAGRA INYECCIÓN	PLASTIC INYECCION HINGE	3	1
31	33.0013.000		PORTACUCHILLAS V. 2.1	BLADE HOLDER V 2.1	1	10
32	115.0000.015		CHAVETA 10X8X25	BOLT 10 x 8 x 25	4	1
33	200.2365.001		BRIDA INTERMEDIA Z100-200	INTERMEDIATE CLAMP Z-100/200	1	1
34	100.0903.127		TORNILLO DIN 912 M8 X 20 INOX	DIN 912 M-8X20 I SCREW	4	1
35	160.0111.312		MOTOR 0,4 CV 220-230 V	0.4CV 220/230V 50/60HZ MOTOR	1	1
36	210.3301.001		PIÑÓN GRANDE PLASTICO	BIG PLASTIC GEAR	2	1
37	210.3302.001		PIÑÓN PEQUEÑO PLASTICO	SMALL PLASTIC GEAR	1	1
38	210.1106.001		PIÑÓN PEQUEÑO METALICO	SMALL METALLIC GEAR	1	1
39	160.0211.049		REDUCTOR 1:60	MVF 49F REL.1:60 REDUCER	1	1
40	33.0024.000		KIT TAMBOR HEMBRA	UPPER PRESSING UNIT KIT	1	1
		2 Ud / 225.3307.001	TAMBOR HEMBRA PLASTICO	UPPER PLASTIC PRESSING UNIT		
41	100.0903.128		TORNILLO DIN 912 M8 X 25 INOX	DIN 912 M-8x25 I. SCREW	1	1
42	100.0903.086		TORNILLO DIN 912 M5 X 15 INOX	DIN 912 M-5x15 I. SCREW	3	1
43	33.0017.000		DEPOSITO CORTEZAS ZX00 (1)	ZX00 PEEL BUCKET (1)	2	1
	13.034.000		DEPOSITO CORTEZAS ZX00 T-MAD (2)	ZX00 PELL BUCKET WOOD (2)	2	1
	13.922.000		DEPOSITO CORTEZAS ZX00 T-GRP (3)	ZX00 PELL BUCKET SILVER (3)	2	1
	13.601.000		DEPOSITO CORTEZAS ZX50 (4)	ZX50 PEEL BUCKET (4)	2	1
	13.038.000		DEPOSITO CORTEZAS ZX50 T-MAD (5)	ZX50 PEEL BUCKET T-MAD (5)	2	1
	13.927.000		DEPOSITO CORTEZAS ZX50 T-GRP (6)	ZX50 PEEL BUCKET SIVER (6)	2	1
44	100.0909.129		TORNILLO DIN 7991 M-8X30 I	DIN 7991 M-8x30 I SCREW	8	1
47	260.3327.001		FILTRO BANDEJA POSAVASOS (1) (4)	Z-100/200 TRAY FILTER (1) (4)	1	1
	13.926.000		FILTRO POSAV ZX00 T-GRP (2) (3) (5) (6)	Z100/200 TRAY FILTER SILVER (2) (3) (5) (6)	1	1
48	260.3328.001		BANDEJA POSAVASOS (1) (4)	Z-100/200 DRAIN TRAY (1) (4)	1	1
	260.3341.000		BANDEJA POSAV Z100/200 GRAF (2) (3) (5) (6)	Z100/200 DRAIN TRAY BLACK (2) (3) (5) (6)	1	1
50	105.0916.008		ARANDELA DIN 9021 M8 INOX	DIN 9021 D8 I WASHER	4	1
51	105.0910.006		ARANDELA DIN 125 M6 FORMA A	DIN 125 D6 I WASHER	4	1
52	100.1901.008		TUERCA DIN 934 M8 INOX	DIN 934 M-8 I. NUT	4	1
53	33.0003.001		KIT VOLANTES EXPRIMI TPE	TPE SECURING KNOBS KIT	2	25
		2 Ud / 200.3306.004	VOLANTE PLASTICO INYECCION	SECURING KNOBS		
54	33.0045.001		CUBIERTA ZUMEX PLATA 100/200	ZUMEX 100 / 200 SILVER COVER	1	5
55	33.0001.000		CUÑA EXTRACTORA DERECHA	RIGHT PEEL EJECTOR (PIVOTS)	1	48
56	33.0023.001		CUBETA ZUMO FUME Z-100/200	Z100/200 FILTER HOLDER	1	1
57	33.0002.000		CUÑA EXTRACTORA IZQUIERDA	LEFT PEEL EJECTOR (PIVOTS)	1	48
58	33.0014.000		FILTRO CUBETA Z 100/200	Z100/200 FILTER	1	40

60	13.651.000		CAJA CIRCUITO	ELECTRONIC MODULE BOX	1	1
63	120.0019.000		TAPON ALLEN M5 NEGRO	ALLEN M-5 CAP BLACK	3	1
64	100.0935.043		TORNILLO DIN 7985 M3X8 I	DIN 7985 M-3X8I SCREW	2	1
65	220.4901.000		PASAMUROS TAPA TRASERA	REAR COVER SINGLE BUSHING	1	1
67	33.0028.000		CIERRE CUBIERTA Z100/200 C/TOR KIT	Z100/200 COVER LOCK WITH SCREW KIT	1	120
		1 Ud / 120.0004.001	CIERRE 97-30-160-12	LOCK 97-30-160-12		
		2 Ud / 100.0935.043	TORNILLO DIN 7985 M3 X 8 I	DIN 7985 M3 X 8 I SCREW		
68	100.2000.000		TORNILLO ESPECIAL HEYCO 07441	HEYCO SPECIAL SCREW 0744151	6	1
69	155.0004.009		CAJA CONECTORA 3 VIAS PORTAHEMBRA	3 WAYS FEMALE CONECTOR	2	1
70	155.0028.002		SUJETACABLES AUTOADHESIVO	FLAT CABLE CLIP FC-15-0	2	1
73	155.0003.001		CABLE CON CLAVIJA 3 X 1 2,5 MTS	CABLE WITH PLUG 3x1 2'5 Mts.	1	1
	155.0003.006		CABLE CON CLAVIJA GB (7)	CABLE WITH PLUG GB (7)	1	1
	155.0003.004		CABLE CON CLAVIJA ARG (8)	CABLE WITH PLUG ARG (8)	1	1
	155.0003.002		CABLE CON CLAVIJA AUS (9)	CABLE WITH PLUG AUS (9)	1	1
74	100.1601.012		TUERCA DIN 934 M12 NYLON	DIN 934 M-12 NYLON NUT	1	1
75	155.0051.000		DETECTOR MAGNETICO L=600 MM	MAGNETIC DETECTOR L=600 mm.	1	1
77	220.4709.003		PERFIL CUBIERTA CON FILETES	COVER SILICONE STRIP	1,5 m	1
79	33.0037.000		KIT TUBO ALIMENTACIÓN Z100	Z100 FEEDER TUBE KIT	1	1
		1 Ud / 225.0920.002	TUBO Z-100	FEEDING TUBE Z-100		
		2 Ud / 100.0903.086	TORNILLO DIN 912 M5 X 16 I	DIN 912 M5 X 16 I SCREW		
		2 Ud / 120.0019.000	TAPON ALLEN M5 NEGRO	ALLEN M5 CAP BLACK		
80	250.1114.001		EJE REDUCTOR Z-10	Z-10 REDUCER SHAFT	1	1
81	33.0043.000		MÓDULO ELECTRÓNICO 230V ON/OFF	230V ON/OFF ELECTR. MODULE	1	5
82	220.3454.002		TAPA TRASERA Z-100 (1) (4)	Z100 REAR COVER INJECTION (1) (4)	1	1
	13.037.000		TAPA TRASERA INY Z100 T-MAD (2) (5)	WOOD Z100 REAR COVER INJECTION (2) (5)	1	1
	220.3463.002		TAPA TRASERA INY Z100 GRAF (3) (6)	GRAPHITE REAR COVER Z100 (3) (6)	1	1
83	120.0007.012		TAPON GPN910/3280 NEGRO	GPN CAP 910/3280 D12	1	1
84	155.0017.003		PULSADOR I/O ZB4-BL8434	NC/NO ZB4BZ105 BODY BUTTON	1	1
85	155.0017.005		CUERPO PULSADOR NC-NO ZB4Z105	NC/NO ZB4BZ105 BODY BUTTON	1	1
86	33.0059.000		GOMA PROTECC. PULSADOR Z100	Z100 BUTTON RUBBER PROTECTION	1	40
87	13.366.000		BUS PULSADOR MECANICO	MECHANICAL SWITCH BUS	1	1
88	171.1807.000		JUNTA ESP SILICONA MSF 18,5 X 7 X 3,5	SILIC.MFS JOINT 18,5x7x3,5	1	1
89	171.2418.000		JUNT.SILIC.MFS 24,5 X 18,5 X 3,5	SILIC.MFS JOINT 24,5 X 18,5 X 4,5	1	1

(1) ZUMEX 100 230 V

(2) ZUMEX 100 230 V MADERA / WOOD

(3) ZUMEX 100 230 V GRIS PLATA / SILVER GRAY

(4) ZUMEX 100 230 V BA

(5) ZUMEX 100 230 V BA MADERA / BA WOOD

(6) ZUMEX 100 230 V BA GRIS PLATA / BA SILVER GRAY

(7) ZUMEX 100 230 V MODELOS GB / GB MODELS

(8) ZUMEX 100 230 V MODELOS AR / AR MODELS

(9) ZUMEX 100 240 V MODELOS AUS / AUS MODELS

ESQUEMA ELECTRONICO Z 100  
Z 100 ELECTRONIC DIAGRAM

